

CCNA 200-301 Day 6

Ethernet LAN Switching (Part 2)

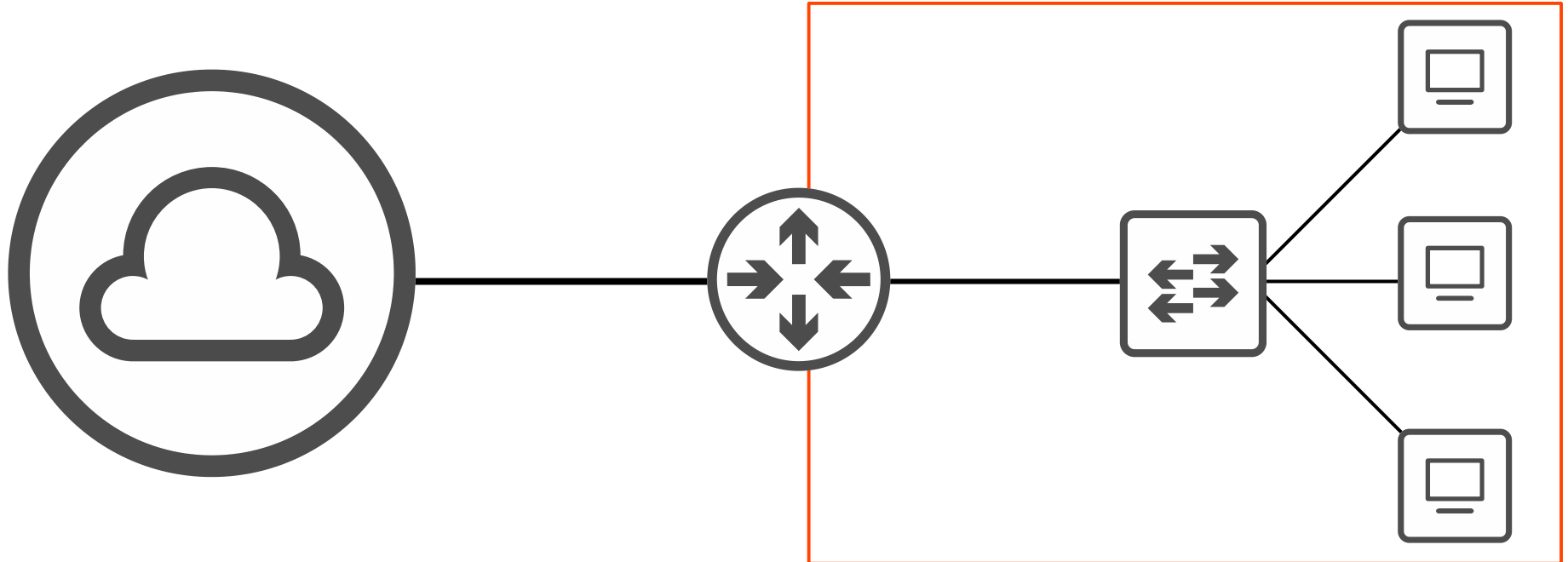

Ethernet Frame

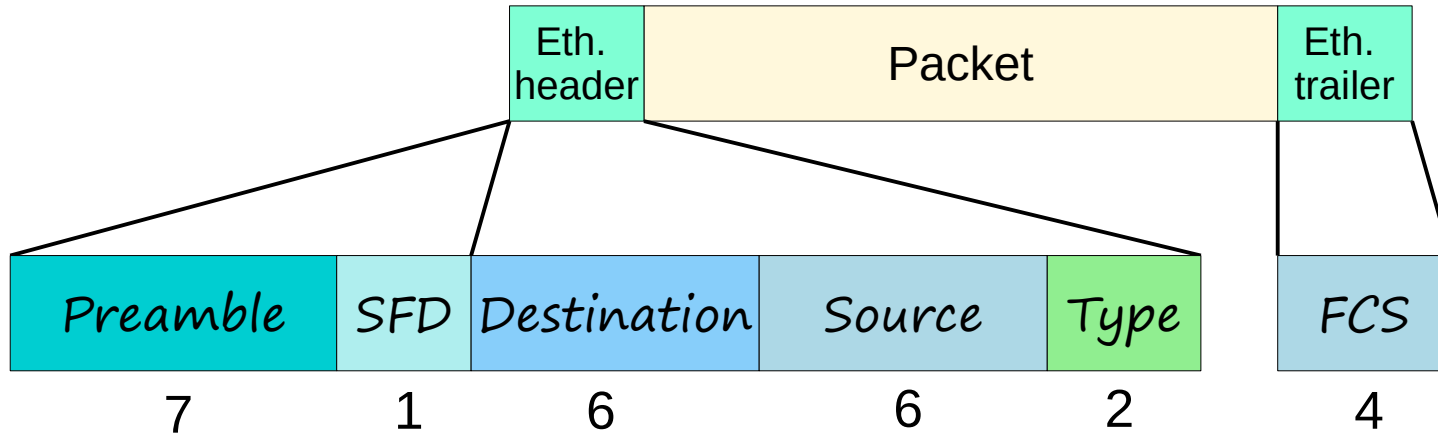

- The **Preamble** + **SFD** is usually not considered part of the Ethernet header
- Therefore the size of the Ethernet header + trailer is 18 bytes
(6 + 6 + 2 + 4)

Ethernet Frame

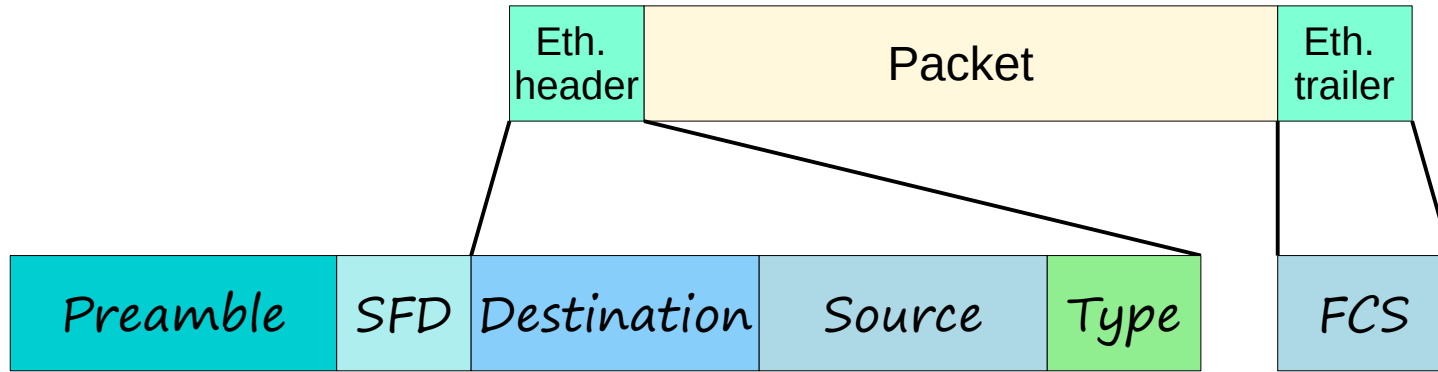

- The minimum size for an Ethernet frame (Header + Payload [Packet] + Trailer) is **64 bytes**
- **64 bytes** – **18 bytes** (header + trailer size) = **46 bytes**
- Therefore the minimum payload (packet) size is **46 bytes**
- If the payload is less than **46 bytes**, padding bytes are added
- ie. **34-byte packet** + **12-byte padding** = **46 bytes**

Ethernet LAN Switching

MAC: 0C2F.B011.9D00

MAC: 0C2F.B06A.3900

192.168.1.0/24

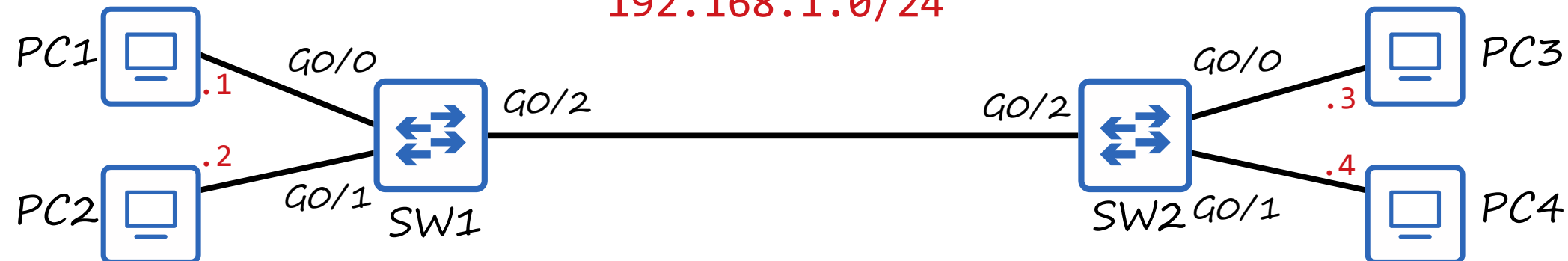

MAC: 0C2F.B084.6200

MAC: 0C2F.B01E.0A00

SW1 MAC Address Table

MAC	Interface

SW2 MAC Address Table

MAC	Interface

Ethernet LAN Switching

MAC: 0C2F.B011.9D00

MAC: 0C2F.B06A.3900

192.168.1.0/24

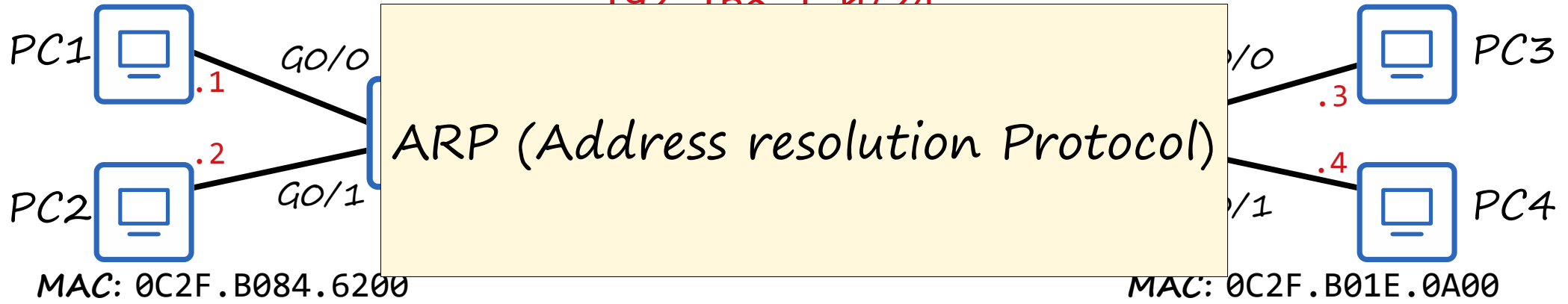

SW1 MAC Address Table

MAC	Interface

Src IP: 192.168.1.1
 Dst IP: 192.168.1.3
 Src MAC: .9D00
 Dst MAC: ???

SW2 MAC Address Table

MAC	Interface

ARP

- ARP stands for 'Address Resolution Protocol'
- ARP is used to discover the Layer 2 address (MAC address) of a known Layer 3 address (IP address)
- Consists of two messages:

ARP Request

ARP Reply

- ARP Request is broadcast = sent to all hosts on the network
- ARP Reply is unicast = sent only to one host (the host that sent the request)

ARP Request

MAC: 0C2F.B011.9D00

MAC: 0C2F.B06A.3900

192.168.1.0/24

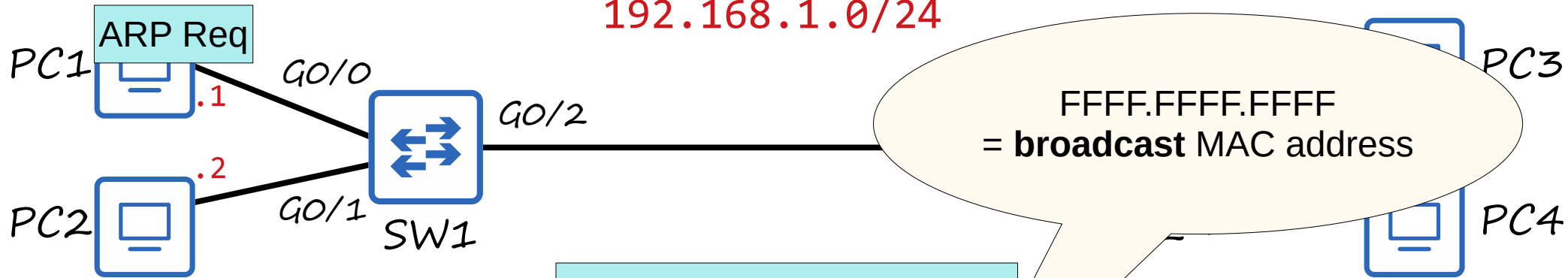

FFFF.FFFF.FFFF
= broadcast MAC address

ARP REQUEST
Src IP: 192.168.1.1
Dst IP: 192.168.1.3
Src MAC: 0C2F.B011.9D00
Dst MAC: FFFF.FFFF.FFFF

Src IP: 192.168.1.1
Dst IP: 192.168.1.3
Src MAC: .9D00
Dst MAC: ???

SW1 MAC Address Table

MAC	Interface

SW2 MAC Address Table

MAC	Interface

ARP Request

MAC: 0C2F.B011.9D00

MAC: 0C2F.B06A.3900

192.168.1.0/24

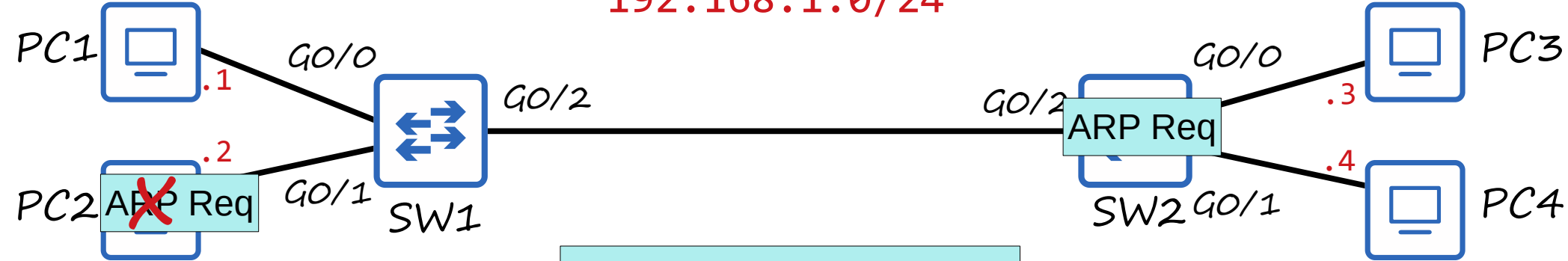

MAC: 0C2F.B084.6200

MAC: 0C2F.B01E.0A00

SW1 MAC Address Table

MAC	Interface
.9D00	G0/0

ARP REQUEST

dynamic MAC address

SW2 MAC Address Table

MAC	Interface

Src IP: 192.168.1.1
 Dst IP: 192.168.1.3
 Src MAC: .9D00
 Dst MAC: ???

ARP Request

MAC: 0C2F.B011.9D00

MAC: 0C2F.B06A.3900

192.168.1.0/24

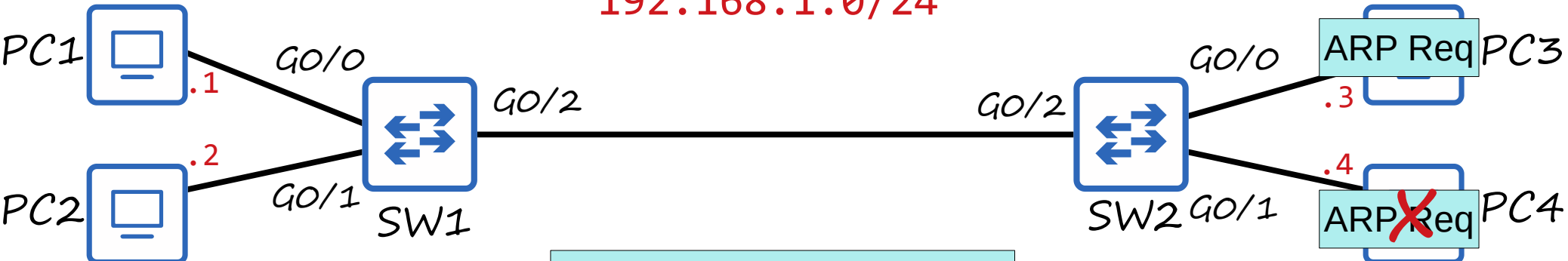

MAC: 0C2F.B084.6200

MAC: 0C2F.B01E.0A00

SW1 MAC Address Table

MAC	Interface
.9D00	G0/0

ARP REQUEST
 Src IP: 192.168.1.1
 Dst IP: 192.168.1.3
 Src MAC: 0C2F.B011.9D00
 Dst MAC: FFFF.FFFF.FFFF

Src IP: 192.168.1.1
 Dst IP: 192.168.1.3
 Src MAC: .9D00
 Dst MAC: ???

SW2 MAC Address Table

MAC	Interface
.9D00	G0/2

ARP Reply

MAC: 0C2F.B011.9D00

MAC: 0C2F.B06A.3900

192.168.1.0/24

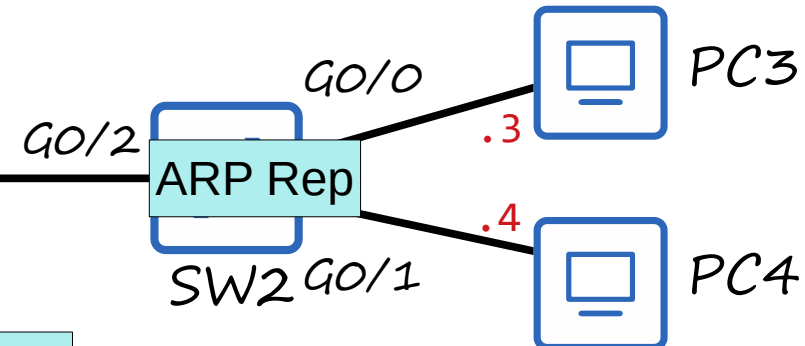
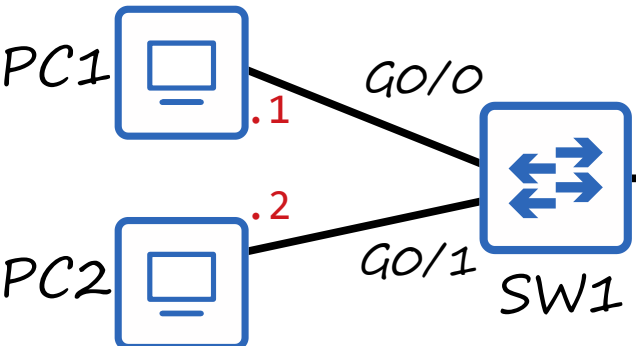

MAC: 0C2F.B084.6200

MAC: 0C2F.B01E.0A00

SW1 MAC Address Table

MAC	Interface
.9D00	G0/0

ARP REPLY

Src IP: 192.168.1.3
 Dst IP: 192.168.1.1
 Src MAC: 0C2F.B06A.3900
 Dst MAC: 0C2F.B011.9D00

Src IP: 192.168.1.1
 Dst IP: 192.168.1.3
 Src MAC: .9D00
 Dst MAC: ???

SW2 MAC Address Table

MAC	Interface
.9D00	G0/2

ARP Reply

MAC: 0C2F.B011.9D00

MAC: 0C2F.B06A.3900

192.168.1.0/24



MAC: 0C2F.B084.6200

SW1 MAC Address Table

MAC	Interface
.9D00	G0/0

ARP REPLY

Src IP: 192.168.1.3
 Dst IP: 192.168.1.1
 Src MAC: 0C2F.B06A.3900
 Dst MAC: 0C2F.B011.9D00

Src IP: 192.168.1.1
 Dst IP: 192.168.1.3
 Src MAC: .9D00
 Dst MAC: ???

known unicast frame
 = forward (not flood)

SW2 MAC Address Table

MAC	Interface
.9D00	G0/2
.3900	G0/0

ARP Reply

MAC: 0C2F.B011.9D00

MAC: 0C2F.B06A.3900

192.168.1.0/24

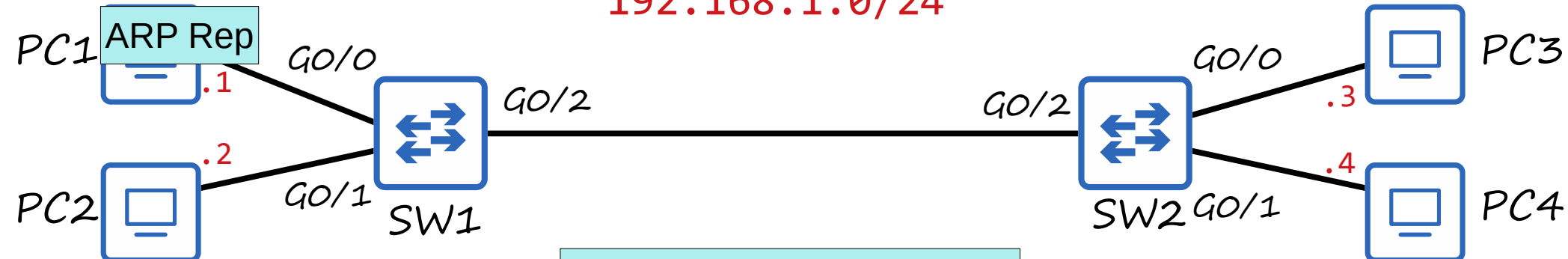

MAC: 0C2F.B084.6200

MAC: 0C2F.B01E.0A00

SW1 MAC Address Table

MAC	Interface
.9D00	G0/0
.3900	G0/2

ARP REPLY

Src IP: 192.168.1.3
 Dst IP: 192.168.1.1
 Src MAC: 0C2F.B06A.3900
 Dst MAC: 0C2F.B011.9D00

Src IP: 192.168.1.1
 Dst IP: 192.168.1.3
 Src MAC: .9D00
 Dst MAC: ???

SW2 MAC Address Table

MAC	Interface
.9D00	G0/2
.3900	G0/0

ARP Table

```
C:\Users\user>arp -a
```

```
Interface: 169.254.146.29 --- 0x9
```

Internet Address	Physical Address	Type
169.254.255.255	ff-ff-ff-ff-ff-ff	static
224.0.0.2	01-00-5e-00-00-02	static
224.0.0.22	01-00-5e-00-00-16	static
224.0.0.251	01-00-5e-00-00-fb	static
224.0.0.252	01-00-5e-00-00-fc	static
239.255.255.250	01-00-5e-7f-ff-fa	static
255.255.255.255	ff-ff-ff-ff-ff-ff	static

```
Interface: 192.168.0.167 --- 0xd
```

Internet Address	Physical Address	Type
192.168.0.1	98-da-c4-dd-a8-e4	dynamic
192.168.0.255	ff-ff-ff-ff-ff-ff	static
224.0.0.2	01-00-5e-00-00-02	static
224.0.0.22	01-00-5e-00-00-16	static
224.0.0.251	01-00-5e-00-00-fb	static
224.0.0.252	01-00-5e-00-00-fc	static
239.255.255.250	01-00-5e-7f-ff-fa	static
255.255.255.255	ff-ff-ff-ff-ff-ff	static

- Use `arp -a` to view the ARP table (Windows, macOS, Linux)
- Internet Address = IP address (Layer 3 address)
- Physical Address = MAC address (Layer 2 address)
- Type `static` = default entry
- Type `dynamic` = learned via ARP

Ethernet LAN Switching

MAC: 0C2F.B011.9D00
PC1
.1
Gi0/0

MAC: 0C2F.B06A.3900
PC3
.3
Gi0/0

MAC: 0C2F.B084.6200
PC2
.2
Gi0/0

MAC: 0C2F.B01E.0A00
PC4
.4
Gi0/0

SW1

SW2

192.168.1.0/24

Gi0/0

Gi0/1

Gi0/2

Gi0/2

gns3.com

File Edit View Control Node Annotate Tools Help

Topology Summary

Node	Console
PC1	telnet 192.168.234.128...
PC2	telnet 192.168.234.128...
PC3	telnet 192.168.234.128...
PC4	telnet 192.168.234.128...
SW1	telnet 192.168.234.128...
SW2	telnet 192.168.234.128...

Servers Summary

- dell-PC CPU 11.1%, RAM 57.3%
- GNS3 VM (GNS3 VM) CPU 26.7%, RAM 19.0%

Console

GNS3 management console.
Running GNS3 version 2.12.1 on Windows (64-bit) with Python 3.8.8 Qt 5.12.1 and PyQt 5.12.
Copyright (c) 2008-2019 GNS3 Technologies.
Use Help -> GNS3 Doctor to detect common issues.

=> Can't create the link: the port is not free

1 warning

Ethernet LAN Switching

MAC: 0C2F.B011.9D00

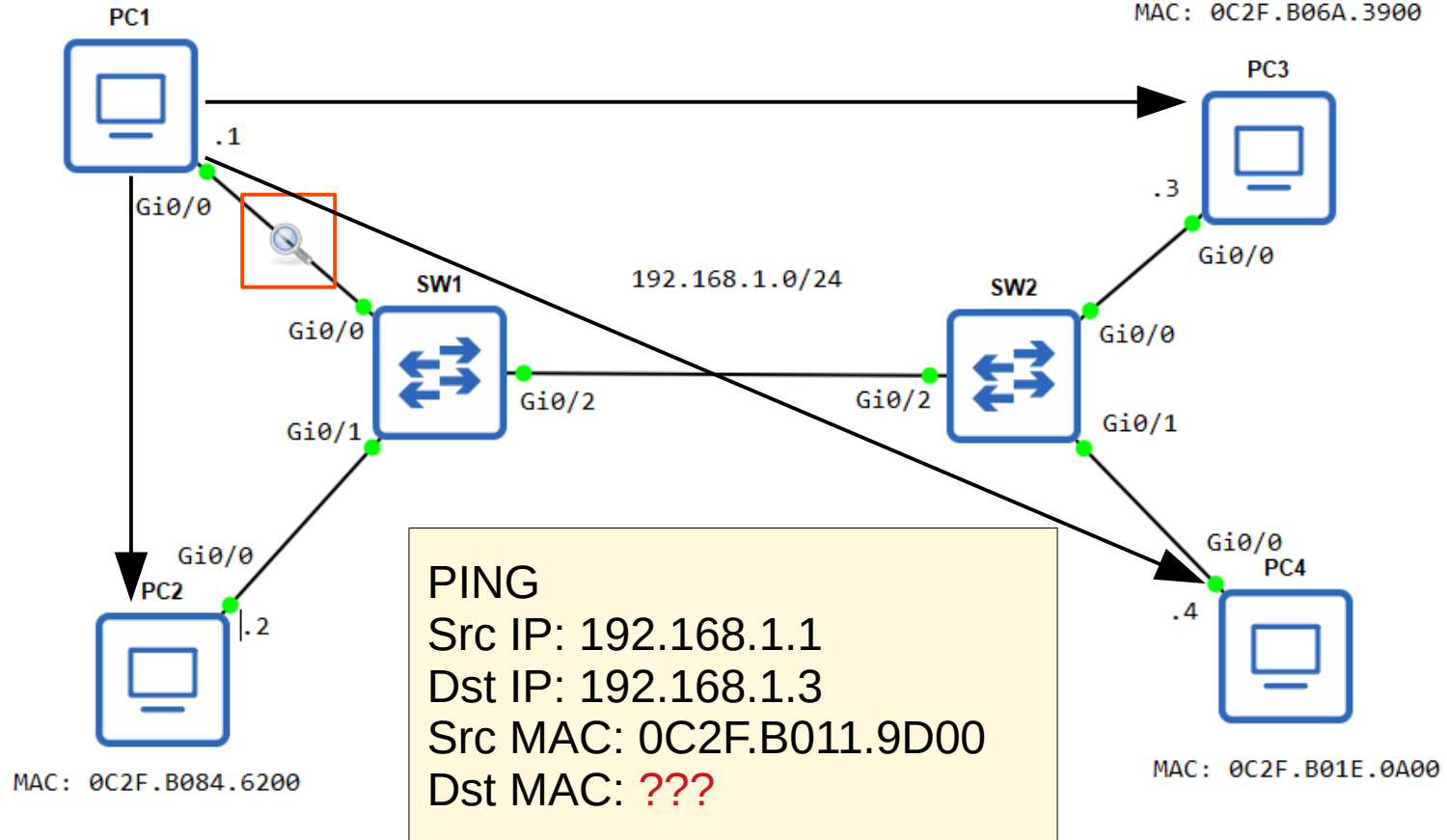

Ethernet LAN Switching

MAC: 0C2F.B011.9D00

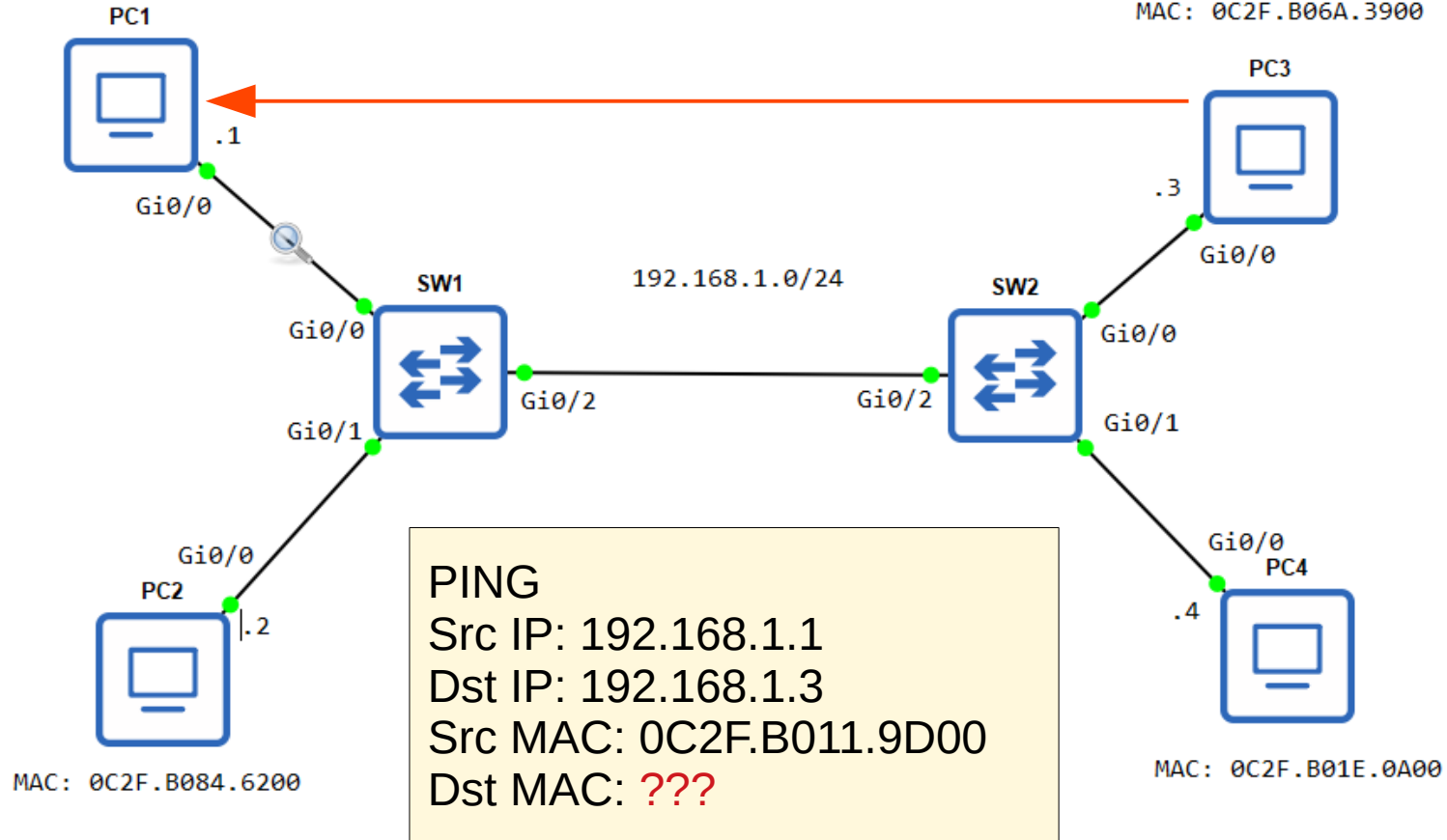

Ethernet LAN Switching

MAC: 0C2F.B011.9D00

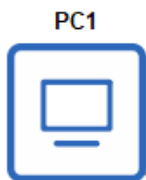

.1

Gi0/0

MAC: 0C2F.B06A.3900



.3

Gi0/0

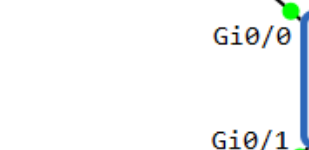

192.168.1.0/24

Gi0/0

Gi0/2

Gi0/2



Gi0/0

Gi0/1

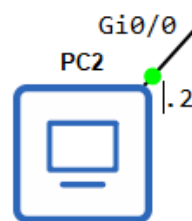

.2

Gi0/0

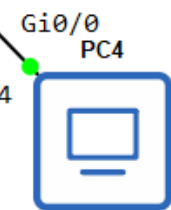

.4

Gi0/0

MAC: 0C2F.B084.6200

MAC: 0C2F.B01E.0A00

PING
Src IP: 192.168.1.1
Dst IP: 192.168.1.3
Src MAC: 0C2F.B011.9D00
Dst MAC: 0C2F.B06A.3900

Ping

- A network utility that is used to test reachability
- Measures round-trip time
- Uses two messages:

ICMP Echo Request

ICMP Echo Reply

- Command to use ping: `ping (ip-address)`

```
PC1#  
PC1#ping 192.168.1.3  
Type escape sequence to abort.  
Sending 5, 100-byte ICMP Echos to 192.168.1.3, timeout is 2 seconds:  
.!!!!  
Success rate is 80 percent (4/5), round-trip min/avg/max = 20/20/22 ms  
PC1#
```

```
PC1#show arp  
Protocol  Address          Age (min)  Hardware Addr  Type   Interface  
Internet  192.168.1.1      -         0c2f.b011.9d00  ARPA   GigabitEthernet0/0  
Internet  192.168.1.3     34        0c2f.b06a.3900  ARPA   GigabitEthernet0/0  
PC1#
```

Capturing from - [PC1 Gi0/0 to SW1 Gi0/0]

File Edit View Go Capture Analyze Statistics Telephony Wireless Tools Help



Apply a display filter ... <Ctrl-F>

No.	Time	Source	Destination	Protocol	Length	Info
1	0.000000	0c:2f:b0:11:9d:00	DEC-MOP-Remote-Cons...	0x6002	77	DEC DNA Remote Console
2	10.593169	0c:2f:b0:11:9d:00	Broadcast	ARP	60	Who has 192.168.1.3? Tell 192.168.1.1
3	10.626235	0c:2f:b0:6a:39:00	0c:2f:b0:11:9d:00	ARP	60	192.168.1.3 is at 0c:2f:b0:6a:39:00
4	12.594539	192.168.1.1	192.168.1.3	ICMP	114	Echo (ping) request id=0x0000, seq=1/256,
5	12.611613	192.168.1.3	192.168.1.1	ICMP	114	Echo (ping) reply id=0x0000, seq=1/256,
6	12.615710	192.168.1.1	192.168.1.3	ICMP	114	Echo (ping) request id=0x0000, seq=2/512,
7	12.635834	192.168.1.3	192.168.1.1	ICMP	114	Echo (ping) reply id=0x0000, seq=2/512,
8	12.638777	192.168.1.1	192.168.1.3	ICMP	114	Echo (ping) request id=0x0000, seq=3/768,
9	12.657810	192.168.1.3	192.168.1.1	ICMP	114	Echo (ping) reply id=0x0000, seq=3/768,
10	12.662283	192.168.1.1	192.168.1.3	ICMP	114	Echo (ping) request id=0x0000, seq=4/1024,
11	12.679631	192.168.1.3	192.168.1.1	ICMP	114	Echo (ping) reply id=0x0000, seq=4/1024,
12	61.223287	0c:2f:b0:84:62:00	DEC-MOP-Remote-Cons...	0x6002	77	DEC DNA Remote Console
13	556.051745	0c:2f:b0:1e:0a:00	DEC-MOP-Remote-Cons...	0x6002	77	DEC DNA Remote Console
14	575.410010	0c:2f:b0:6a:39:00	DEC-MOP-Remote-Cons...	0x6002	77	DEC DNA Remote Console

MAC Address Table

```
SW1#show mac address-table
```

```
Mac Address Table
```

```
-----
```

Vlan	Mac Address	Type	Ports
----	-----	-----	-----
1	0c2f.b011.9d00	DYNAMIC	Gi0/0
1	0c2f.b06a.3900	DYNAMIC	Gi0/2

```
Total Mac Addresses for this criterion: 2
```

```
SW1#
```

MAC Address Table

MAC: 0C2F.B011.9D00

MAC: 0C2F.B06A.3900

192.168.1.0/24

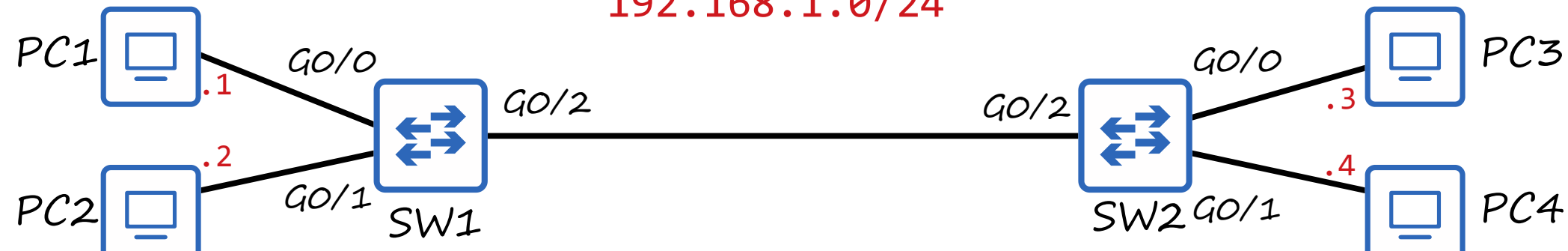

MAC: 0C2F.B084.6200

SW1 MAC Address Table

MAC	Interface
.9D00	G0/0
.3900	G0/2

```
SW1#show mac address-table
Mac Address Table
```

```
-----
```

Vlan	Mac Address	Type	Ports
1	0c2f.b011.9d00	DYNAMIC	Gi0/0
1	0c2f.b06a.3900	DYNAMIC	Gi0/2

```
-----
```

Total Mac Addresses for this criterion: 2

SW1#

Clearing the MAC Address Table

```
SW1#show mac address-table
      Mac Address Table
```

Aging

```
-----
Vlan    Mac Address      Type      Ports
```

```
clear mac address-table dynamic
```

```
Total Mac Addresses for this criterion: 2
```

```
SW1#clear mac address-table dynamic
```

```
SW1#show mac address-table
      Mac Address Table
```

```
-----
Vlan    Mac Address      Type      Ports
-----
```

```
SW1#
```

Clearing the MAC Address Table

```
SW1#show mac address-table
      Mac Address Table
-----
```

```
Vlan    Mac Address      Type      Ports
-----
```

```
clear mac address-table dynamic address mac-address
```

```
SW1#clear mac address-table dynamic address 0c2f.b011.9d00
```

```
SW1#show mac address-table
      Mac Address Table
-----
```

```
Vlan    Mac Address      Type      Ports
-----
```

```
-----
 1      0c2f.b06a.3900   DYNAMIC   Gi0/2
```

```
Total Mac Addresses for this criterion: 1
```

```
SW1#
```

Clearing the MAC Address Table

```
SW1#show mac address-table  
      Mac Address Table
```

```
-----  
Vlan    Mac Address      Type      Ports
```

```
clear mac address-table dynamic interface interface-id
```

```
SW1#clear mac address-table dynamic interface Gi0/0
```

```
SW1#show mac address-table  
      Mac Address Table
```

```
-----  
Vlan    Mac Address      Type      Ports
```

```
-----  
1       0c2f.b06a.3900   DYNAMIC   Gi0/2
```

```
Total Mac Addresses for this criterion: 1
```

```
SW1#
```

Ethernet Frame

```
PC1#ping 192.168.1.3 size 36
```

Wireless Tools Help

Apply a display filter ... <Ctrl-/>

No.	Time	Source	Destination	Protocol	Length	Info
17	8.111111	192.168.1.1	192.168.1.3	ICMP	60	Echo (ping) request
18	8.111111	192.168.1.3	192.168.1.1	ICMP	60	Echo (ping) reply
19	8.111111	192.168.1.1	192.168.1.3	ICMP	60	Echo (ping) request
20	8.111111	192.168.1.3	192.168.1.1	ICMP	60	Echo (ping) reply
21	39.092085	192.168.1.1	192.168.1.3	ICMP	60	Echo (ping) request
22	39.092085	192.168.1.3	192.168.1.1	ICMP	60	Echo (ping) reply
23	41.092085	192.168.1.1	192.168.1.3	ICMP	60	Echo (ping) request
24	41.092085	192.168.1.3	192.168.1.1	ICMP	60	Echo (ping) reply
25	41.092085	192.168.1.1	192.168.1.3	ICMP	60	Echo (ping) request
26	41.974209	192.168.1.3	192.168.1.1	ICMP	60	Echo (ping) reply
27	42.092085	192.168.1.1	192.168.1.3	ICMP	60	Echo (ping) request
28	42.182209	192.168.1.3	192.168.1.1	ICMP	60	Echo (ping) reply
29	42.327008	192.168.1.1	192.168.1.3	ICMP	60	Echo (ping) request
30	42.388165	192.168.1.3	192.168.1.1	ICMP	60	Echo (ping) reply

> Frame 23: 60 bytes on wire (480 bits), 60 bytes captured (480 bits) on interface 0

▼ Ethernet II, Src: 0c:2f:b0:11:9d:00 (0c:2f:b0:11:9d:00), Dst: 0c:2f:b0:6a:39:00 (0c:2f:b0:6a:39:00)

- > Destination: 0c:2f:b0:6a:39:00 (0c:2f:b0:6a:39:00)
- > Source: 0c:2f:b0:11:9d:00 (0c:2f:b0:11:9d:00)
- Type: IPv4 (0x0800)
- Padding: 000000000000000000000000

Ethernet Frame

29	42.327008	192.168.1.1	192.168.1.3	ICMP	60	Echo (ping) request	id=0:
30	42.388165	192.168.1.3	192.168.1.1	ICMP	60	Echo (ping) reply	id=0:
31	524.651742	0c:2f:b0:1e:0a:00	DEC-MOP-Remote-Cons...	0x6002	77	DEC DNA Remote Console	
32	528.483094	0c:2f:b0:84:62:00	DEC-MOP-Remote-Cons...	0x6002	77	DEC DNA Remote Console	
33	533.098827	0c:2f:b0:11:9d:00	DEC-MOP-Remote-Cons...	0x6002	77	DEC DNA Remote Console	
34	651.573757	0c:2f:b0:6a:39:00	DEC-MOP-Remote-Cons...	0x6002	77	DEC DNA Remote Console	

- > Frame 23: 60 bytes on wire (480 bits), 60 bytes captured (480 bits) on interface 0
- ▼ Ethernet II, Src: 0c:2f:b0:11:9d:00 (0c:2f:b0:11:9d:00), Dst: 0c:2f:b0:6a:39:00 (0c:2f:b0:6a:39:00)
 - > Destination: 0c:2f:b0:6a:39:00 (0c:2f:b0:6a:39:00)
 - > Source: 0c:2f:b0:11:9d:00 (0c:2f:b0:11:9d:00)
 - Type: IPv4 (0x0800)
 - Padding: 00000000000000000000
- > Internet Protocol Version 4, Src: 192.168.1.1, Dst: 192.168.1.3
- > Internet Control Message Protocol

```

0000  0c 2f b0 6a 39 00 0c 2f  b0 11 9d 00 08 00 45 00  ./.j9../ .....E.
0010  00 24 00 01 00 00 ff 01  38 83 c0 a8 01 01 c0 a8  -$. .... 8.....
0020  01 03 08 00 a1 64 00 00  00 01 00 00 00 00 00 01  .....d.....
0030  56 99 00 00 00 00 00 00  00 00 00 00  V.....
  
```

Ethernet Frame

- > Frame 22: 60 bytes on wire (480 bits), 60 bytes captured (480 bits) on interface
- > Ethernet II, Src: 0c:2f:b0:6a:39:00 (0c:2f:b0:6a:39:00), Dst: 0c:2f:b0:11:9d:00 (0c:2f:b0:11:9d:00)
 - > Destination: 0c:2f:b0:11:9d:00 (0c:2f:b0:11:9d:00)
 - > Source: 0c:2f:b0:6a:39:00 (0c:2f:b0:6a:39:00)
 - Type: ARP (0x0806)
 - Padding: 00
 - > Address Resolution Protocol (reply)

28	42.182209	192.168.1.3	192.168.1.1	ICMP	60	Echo
29	42.327008	192.168.1.1	192.168.1.3	ICMP	60	Echo
30	42.388165	192.168.1.3	192.168.1.1	ICMP	60	Echo
31	524.651742	0c:2f:b0:1e:0a:00	DEC-MOP-Remote-Cons...	0x6002	77	DEC
32	528.483094	0c:2f:b0:84:62:00	DEC-MOP-Remote-Cons...	0x6002	77	DEC
33	533.098827	0c:2f:b0:11:9d:00	DEC-MOP-Remote-Cons...	0x6002	77	DEC
34	651.573757	0c:2f:b0:6a:39:00	DEC-MOP-Remote-Cons...	0x6002	77	DEC

- > Frame 22: 60 bytes on wire (480 bits), 60 bytes captured (480 bits) on interface
- > Ethernet II, Src: 0c:2f:b0:6a:39:00 (0c:2f:b0:6a:39:00), Dst: 0c:2f:b0:11:9d:00 (0c:2f:b0:11:9d:00)
 - > Destination: 0c:2f:b0:11:9d:00 (0c:2f:b0:11:9d:00)
 - > Source: 0c:2f:b0:6a:39:00 (0c:2f:b0:6a:39:00)
 - Type: ARP (0x0806)
 - Padding: 00
 - > Address Resolution Protocol (reply)

Topics we covered

- Ethernet frame payload minimum size
- ARP (Address Resolution Protocol)

ARP Request

ARP Reply

- ARP table
- Ping

ICMP Echo Request

ICMP Echo Reply

- MAC Address Table

QUIZ

Quiz Question 1

You send a 36-byte ping to another computer and perform a packet capture to analyze the network traffic. You notice a long series of bytes of 00000000 at the end of the Ethernet payload. How can you explain these zeroes?

- a) Pings are a series of zeroes.
- b) They are padding bytes.
- c) They are the Ethernet FCS.

The ping you sent was 36 bytes, but the minimum Ethernet payload size is 46 bytes, so a series of padding bytes must be added to meet the minimum payload size.

Quiz Question 2

Which of these messages is sent to all hosts on the local network?

- a) ARP request
- b) ARP reply
- c) ICMP echo request
- d) ICMP echo reply

Quiz Question 2

~~X~~) ARP Reply

The ARP reply message is a unicast message sent to the host that sent the ARP request.

Quiz Question 2

~~X~~) ICMP echo request, ~~X~~) ICMP echo reply

The ICMP echo request is a unicast message used to test the reachability of another specific host. The ICMP echo reply is a unicast reply to the request.

Quiz Question 2

★ a) ARP request

The ARP request message is used to learn the Layer 2 address of a host. Because the Layer 2 address is not yet known, the message has to be broadcast to all hosts on the local network.

Quiz Question 3

Which fields are present in the output of the `show mac address-table` command on a Cisco switch?

- a) MAC Address, Ports
- b) VLAN, MAC Address, Ports
- c) VLAN, MAC Address, Type, Ports
- d) Internet Address, Physical Address, Type

★ c) VLAN, MAC address, Type, Ports

```
SW1#show mac address-table
      Mac Address Table
-----
Vlan    Mac Address      Type      Ports
----    -
1       0c2f.b011.9d00   DYNAMIC   Gi0/0
1       0c2f.b06a.3900   DYNAMIC   Gi0/2
Total Mac Addresses for this criterion: 2
SW1#
```

Quiz Question 3

```
C:\Users\user>arp -a
```

```
Interface: 169.254.146.29 --- 0x9
```

Internet Address	Physical Address	Type
169.254.255.255	ff-ff-ff-ff-ff-ff	static
224.0.0.2	01-00-5e-00-00-02	static
224.0.0.22	01-00-5e-00-00-16	static
224.0.0.251	01-00-5e-00-00-fb	static
224.0.0.252	01-00-5e-00-00-fc	static
239.255.255.250	01-00-5e-7f-ff-fa	static
255.255.255.255	ff-ff-ff-ff-ff-ff	static

```
Interface: 192.168.0.167 --- 0xd
```

Internet Address	Physical Address	Type
192.168.0.1	98-da-c4-dd-a8-e4	dynamic
192.168.0.255	ff-ff-ff-ff-ff-ff	static
224.0.0.2	01-00-5e-00-00-02	static
224.0.0.22	01-00-5e-00-00-16	static
224.0.0.251	01-00-5e-00-00-fb	static
224.0.0.252	01-00-5e-00-00-fc	static
239.255.255.250	01-00-5e-7f-ff-fa	static
255.255.255.255	ff-ff-ff-ff-ff-ff	static

Quiz Question 4

Which types of frames does a switch send out of all interfaces, except the one the frame was received on?

- a) Broadcast, unknown unicast
- b) Broadcast, known unicast
- c) Known unicast, unknown unicast
- d) Broadcast, unknown unicast, known unicast

Quiz Question 4

~~X~~) Broadcast, *known unicast*

~~X~~) *Known unicast*, unknown unicast

~~X~~) Broadcast, unknown unicast, *known unicast*

Known unicast frames are sent to a single host. Because the switch already has an entry for the destination in its MAC address table, there is no need to flood the frame out all interfaces.

Quiz Question 4

★ a) Broadcast, unknown unicast

Broadcast frames have a destination address of FFFF.FFFF.FFFF and are sent to all hosts on the local network.

Unknown unicast frames are destined for a single host, however the switch doesn't have an entry for the destination in its MAC address table so it must flood the frame.

Quiz Question 5

Which command is used on a Cisco switch to clear all dynamic MAC addresses on a specific interface from the MAC address table?

- a) `clear mac address-table interface interface-id`
- b) `clear mac-address-table dynamic interface interface-id`
- c) `clear mac-address table dynamic interface interface-id`
- d) `clear mac address-table dynamic interface interface-id`

```
SW1#clear mac address-table dynamic interface Gi0/0
```